



# 横走式单轴伺服气缸机械手

Cross-walking Single Axis Servo Cylinder Robot

ADW-80 / ADW-80s

# 注塑用机械手 TAKE-OUT ROBOT

**ADW-80  
ADW-80s**



## 标准功能 STANDARD FUNCTION

1-99点的位置动作  
Positioning 1-99

取出侧姿势控制)  
Posture control at extract side

不良品排出回路  
Defective product reject circuit

副臂单独动作  
Sub-arm individual motion

胶口途中开放 (去程, 返程)  
Midway runner release (Move, Revert)

模内开放  
Product release within mold

内部存储记忆 (最大30种类型)  
Internal memory (for Max 30 molds)

吸着确认单元 (1回路)  
Additional vacuum sensing unit (1 circuit)

落下测下降低速  
Slow speed descent at release side

横走行待机  
Delayed traverse

输送带启动信号  
Start signal of conveyor

水口落下测下降  
Runner descent at release side

水口侧可动取出  
Runner extraction from moving side

2国语言切换 (中文, 英文)  
Two language exchange (Chinese/English)

## 型式 MODEL

## 单位 UNIT

## ADW-80 ADW-80s

电源 Power Source	V	AC200 ~ 220 ± 10% 50/60Hz	
最大消费电力 Max Power Consumption	KW	0.45	
使用气压 Air Pressure	Mpa	0.5 ~ 0.7	
空气消费量 Air Consumption	NI/cycle	13.3	23.7
驱动方式 Drive System	---	气缸/Air Cylinder	
姿势 (气缸) Posture (Air Cylinder)	---	90°固定 / 90°Fixed	
■ 气缸推力 (气压0.49MPa时) Air Cylinder Driving Force (Air Pressure at 0.49MPa)			
最大可搬重量 Max.Load	Kg	3【含夹具重量 / Incl Chuck Weight】	
姿势力矩 Posture Torque	N · m	8.3	
■ 行程 Stroke			
主臂上下 Main-arm Vertical	mm	800/900/100	800/900/1000
副臂上下 Sub-arm Vertical	mm	---	800/900/1000
前后(主臂,副臂) Crosswise (M,S)	mm	主臂/M 300	主臂/M 300 副臂/S 150
走行 Traverse	mm	1400/1600	
■ 本体重量 Net Weight			
本体 Main Body	Kg	279	
操作盒 Pendant	Kg	1.6	

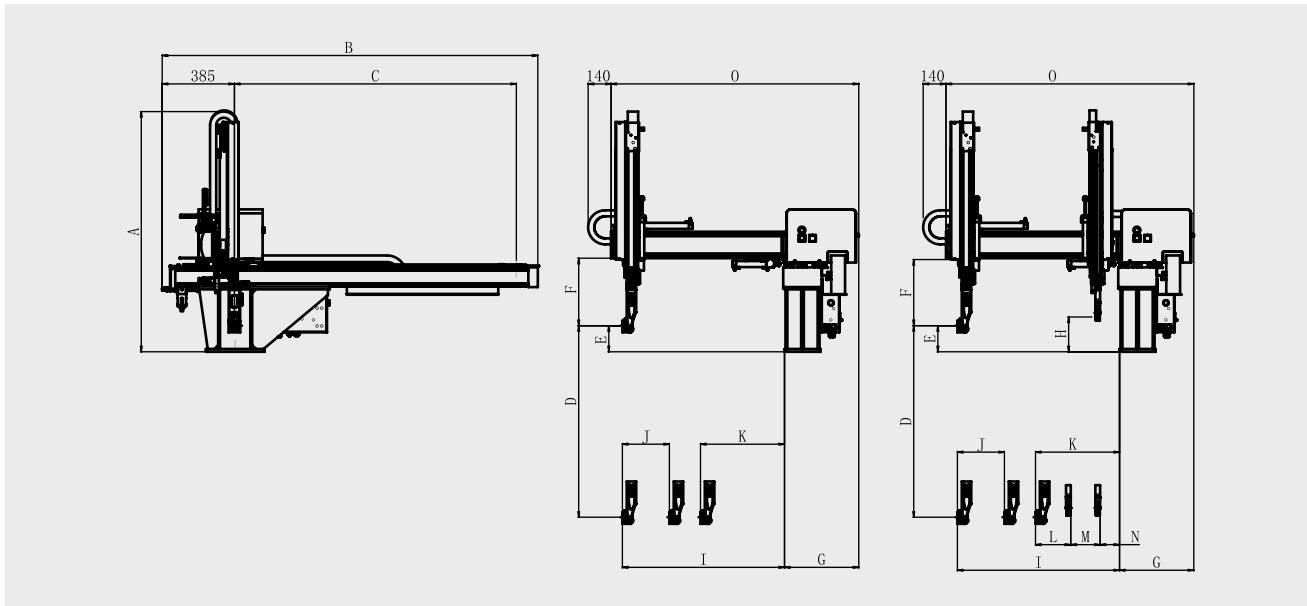

**外形尺寸 OUTER DIMENSIONS**

**ADW-80 ADW-80s**

**选项功能 OPTION FUNCTION**

A	总高 Overall height	1360(1400)(1460)mm	
B	总长 Overall length	1970(2150)mm	
C	走行行程 Traverse stroke	1400(1600)mm	
D	主臂上下行程 Main-arm vertical stroke	800(900)(1000)mm	
E	主臂上下待机 Main-arm vertical standby	165mm	
F	夹具安装有效空间 Bottom of crosswise to chuck mount position	320mm	
G	底座里侧面-箱体末端 Base side face-Box end	385 mm	
H	副臂上下待机 Sub-arm Vertical standby	---	195 mm
I	主臂前进最大值 Main-arm reach max	860 mm	
J	主臂前进最大行程 Main-arm crosswise stroke max	300 mm	300 mm
K	主臂前后待机最小值 Main-arm crosswise standby min	140 mm	285mm
L	主副臂接近最小值 Main/Sub-arm proximity min	---	195 mm
M	副臂前进最大行程 Sub-arm crosswise stroke max	---	150 mm
N	副臂前后待机最小值 Sub-arm crosswise standby min	---	85 mm
O	前后臂末端-箱体末端 Crosswise arm end-Box end	1300 mm	

- ◆ 夹具内剪刀回路  
Air nipper in chuck circuit
- ◆ NT动作剪切装置  
NT gate cut
- ◆ 吸着确认2回路  
Additional vacuum sensing unit ( 2 circuits )
- ◆ 滑移取出  
Under-cut extraction
- ◆ 固定可动切换  
Extraction from fixed side
- ◆ 制品确认  
Product confirmation

- 当尺寸C是1400mm时，尺寸B为1970mm  
• when dimension C is 1400mm , B is 1970mm
- 当尺寸D是800mm时，尺寸A为1320mm  
• when dimension D is 800mm , A is 1320mm
- 当尺寸D是1000mm时，尺寸A为1460mm  
• when dimension D is 1000mm , A is 1460mm

- 当尺寸C是1600mm时，尺寸B为2150mm  
• when dimension C is 1600mm , B is 2150mm
- 当尺寸D是900mm时，尺寸A为1400mm  
• when dimension D is 900mm , A is 1400mm

有关产品性质和适用范围的说明并不保证产品属性，仅作可供了解的信息。我们的供货范围及提供的服务完全以合同条款为准绳。技术数据和插图仅作为供货参考。保留更改权利。

Feature and scope of the product does not guarantee the product attributes, only for reference. Our scope of delivery and services provided are based solely on the terms of delivery and services provided are based solely on the terms of the contract. Technical data and illustration are only for reference. We reserve the rights of changing.

TSD-2021-12

## 广东拓斯达科技股份有限公司

GUANGDONG TOPSTAR TECHNOLOGY CO.,LTD.

地址：广东省东莞市大岭山镇大塘朗创新路2号

ADD : No.2 Chuangxin Road, Datanglang, Dalingshan Town, Dongguan City, Guangdong Province.

电话/TEL: 0769-8305 0999 传真/FAX: 0769-8584 5562

全国统一客服热线 Domestic Service Hotline **400-096-8005**

